

 REFRIGERATOR MANUFACTURER Turbo air more durable, efficient, beautiful	4184 E. Conant St. Long Beach, CA 90808 Tel. 310-900-1000 Fax. 310-900-1077 www.turboairinc.com	Project:	
		Model #:	
		Item #:	
		Available W/H:	Qty:
		Approval:	
		AIA #:	SIS #:
		CSI Section 11400	

Ice Cream Dipping Cabinet

Model : TIDC-47W-N



Back View (Extra storage)

≡ FEATURES & BENEFITS ≡

- **Hydrocarbon refrigerants (R-290)**
 With innovative and eco-friendly technology, Turbo Air brings you hydrocarbon refrigerators designed to meet DOE's Energy Conservation Standards in 2017 and to use EPA's SNAP Program approved HC refrigerants. Hydrocarbon refrigerants do not deplete the ozone layer and have very low contribution to global warming (ODP-0, GWP-3).
- **Locked-in temperature equal from top to bottom**
 New technology of the Cold Wall System eliminates temperature fluctuations throughout the top and bottom areas of the interior cabinet. No more melting ice cream above while freezing below. Scooping has never been easier.
- **5 years cleaning-free condenser**
 1/5" condenser pin gaps and electrodeposition coating allow the condenser to stay clean and prevent it from becoming tarnished, further guaranteeing the durability of the condenser.
- **Low-emissivity front glass and tempered glass sides**
 Energy saving Low-emissivity front glass reduces heat transfer and decreases energy consumption. Reinforced tempered safety glass is equipped on both sides.
- **PE coated removable magnetic frost shields**
 Provides fast and easy removal of accumulated frost on inside walls.
- **LED interior lighting**
 Brighter and longer lasting LED light bulbs produce less heat, saving energy while maximizing display effect. Independent on/off light switch equipped.
- **Attractive contemporary design with curved glass front and top**
 Sleek new curved front and top glass is attractive and draws attention at once. Deep lowered glass front optimizes product visibility and impulse buying. This merchandiser is perfect for ice cream viewing and dipping.
- **Extra storage space**
 Extra storage space accommodates additional ice cream tubs underneath the basket. Doors located to the rear allow easy access to the storage area eliminating inconvenient bracket usage in picking up ice cream tubs.
- **Sturdy, clean stainless steel shelves**
- **Standard plastic night covers for case opening**
- **Manual defrost**
- **Maintains -10°F ~ 8°F for the best in frozen ice cream preservation**



Model	# of Lids	# of Shelves	# of Night Covers	Capacity 3 Gallon(12Liter) cans		HP	AMPS	Crated Weight (lbs.)	L x D x H (inches)
TIDC-47W-N	1	2	2	Total 12	Display - 8 Storage - 4	1/2	4.6	375	47 x 26 1/8 x 50 7/8

Ice Cream Dipping Cabinet

Model : TIDC-47W-N

ELECTRICAL DATA	
Voltage	115/60/1
Plug Type	 NEMA 5-15P
Full Load Amperes	4.6
Compressor HP	1/2
Refrigerant	R-290
DIMENSIONAL DATA	
Capacity (3gal. cans) Display / Storage	8/4
Ext. Length Overall (in.)	47 (1194mm)
Ext. Depth Overall (in.)	26 1/8 (664mm)
Ext. Height Overall (in.)	50 7/8 (1292mm)
# of Lids	1
# of Night Covers	2
# of Shelves	2
Net Weight (lbs.)	297
Gross Weight (lbs.)	375

Design and specifications subject to change without notice.
Actual shipping weight may differ due to extra packing materials for product protection.

■ **WARRANTY : 2 Year Parts and Labor Warranty**
Additional 3 Year Warranty on Compressor

■ STANDARD FEATURES

• Recommended operating conditions

These models are designed to operate in air conditioned environments where temperature and humidity are below 75°F and 55% relative humidity. Place units away from direct sunlight, rapid air movement and extreme temperature changes.

■ OPTIONAL ACCESSORIES

- 2.5" caster, 1/2" diameter & 13 TPI: 30265H0100 (non-brake), 30265H0200 (w/ brake)
- Price tag holder w/ bracket: P0330D0300 (holder), P0306D1700 (bracket)

PLAN VIEW

(unit : inch)

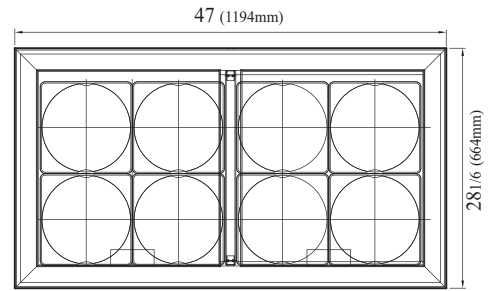

TOP VIEW

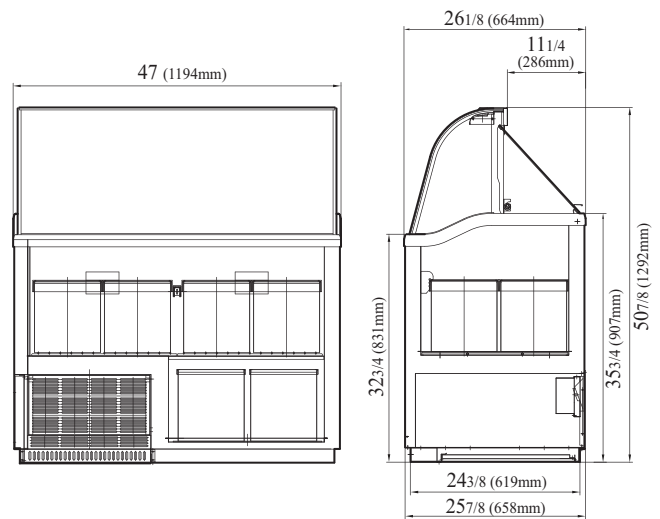

FRONT VIEW

SIDE VIEW

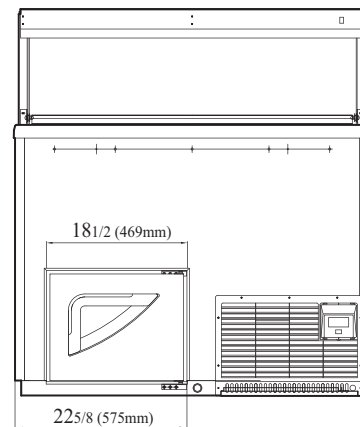

BACK VIEW

Ver.20220819



- Turbo Air : 800-627-0032
- GK : 800-500-3519
- Warranty : 800-381-7770
- AC : 888-900-1002

REFRIGERATOR MANUFACTURER
Turbo air

GERMAN
KNIFE

RADIANCE

REFRIGERATION SYSTEM
Turbo air

Texaking

Continued product development may necessitate specification changes without notice.