

| | |
|-------------------|--------|
| Project: | |
| Model #: | |
| Item #: | |
| Available W/H: | Qty: |
| Approval: | |
| AIA #: | SIS #: |
| CSI Section 11400 | |

Prep Table + Work Station

*Sandwich/Salad Prep
 Super Deluxe Series*

≡ FEATURES & BENEFITS ≡

**Model : TST-72SD-12S-N
 TST-72SD-12S-N-LW**

■ **Self-Cleaning Condenser**

The accumulation of dust in the condenser can cause the failure or breakdown of refrigerators. Refrigerators run normally until they reach a certain level of accumulation. At some point, when they are over the limit, their performance drops quickly resulting in damage to, or disposal of the stored products inside. The Self-Cleaning Condenser device keeps the condenser clean and prevents system failure by automatically brushing daily.

■ **Digital temperature control & monitor system**

Keeps food products safe by maintaining constant temperatures. External digital display allows for easy monitoring.

■ **Hydrocarbon refrigerants (R-290)**

With innovative and eco-friendly technology, Turbo Air brings you hydrocarbon refrigerators designed to meet DOE's Energy Conservation Standards in 2017 and to use EPA's SNAP Program approved HC refrigerants. Hydrocarbon refrigerants do not deplete the ozone layer and have very low contribution to global warming (ODP-0, GWP-3).

■ **Cold Bunker system**

Our innovative forced air system allows cold air to flow all around the food pan area, covering not only underneath the pan, but also the front, top and the rear. This unique air flow creates a cold air-shield around the pan, which maintains the food temperature at under 41°F (NSF requirement) even when the lids are opened. In addition, the compartment isolates pans from the reach-in area to prevent food spillage.

■ **LED interior lighting & fan control**

Energy efficient LED lighting lights every corner, making items easy to find. Fan control function automatically shuts off the fan when the door is open, which prevents hot air from being drawn in, thus maintaining the cool inner temperature.

■ **High-density polyurethane insulation**

The entire cabinet structure and solid doors are foamed-in-place high density, CFC free polyurethane insulation.

■ **Stainless steel cabinet construction**

The Turbo Air Super Deluxe model boasts a stainless steel interior (ABS door liner) and exterior (galvanized steel back & bottom). It guarantees the utmost in cleanliness and long product life. The Super Deluxe adds a touch of style to the most refined setting.

■ **Sturdy, clean stainless steel shelving**

Shelves are the most important part of cleanliness as they come in direct contact with food. After a while, PVC coated wire shelves may peel, rust and lead to unsanitary conditions. Only the Turbo Air Super Deluxe series uniquely provides stainless steel shelving.

■ **Insulated pan cover**

■ **9-1/2" deep, 1/2" thick high-density Polyethylene cutting board included with convenient side rail**



TST-72SD-12S-N



TST-72SD-12S-N-LW

Patented Self-Cleaning Condenser

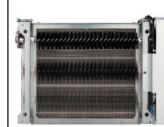

This product is equipped with a fine mesh filter to the front of the condenser to catch dust, and a rotating brush that moves up and down daily to remove excess buildup outward and away.

■ **Refrigerator holds 33°F ~ 39°F for the best in food preservation**

- TST-72SD-12S-N: Right side work station
- TST-72SD-12S-N-LW: Left side work station



| Model | Swing Doors | CU./FT. | #of Shelves | #of Pans | HP | AMPS | Crated Weight (lbs.) | L x D x H† (inches) |
|---------------------|-------------|---------|-------------|----------|-----|------|----------------------|---------------------|
| TST-72SD-12S-N(-LW) | 3 | 23 | 3 | 12 | 3/8 | 9.9 | 392 | 72 5/8 x 30 x 37 |

Model : TST-72SD-12S-N(-LW)

| ELECTRICAL DATA | |
|----------------------------|--|
| Voltage | 115/60/1 |
| Plug Type |  NEMA 5-15P |
| Full Load Amperes | 5.7 |
| Compressor HP | 1/3 |
| Feed Wires with Ground | 3 |
| Cord Length (ft.) | 9 |
| Refrigerant | R-290 |
| DIMENSIONAL DATA | |
| Ext. Length Overall (in.) | 72 ⁵ / ₈ (1846mm) |
| Ext. Depth Overall (in.)* | 30 (762mm) |
| Ext. Height Overall (in.)† | 37 (940mm) |
| # of Doors | 3 |
| # of Shelves | 3 |
| # of Pans | 12 |
| # of Hood | 1 |
| Net Capacity (cu. ft.) | 19 |
| Shelf Size (L x D) (in.) | 21 x 17 (Left/Right) |
| | 23 x 17 (Middle) |
| Net Weight (lbs.) | 344 |
| Gross Weight (lbs.) | 372 |

Design and specifications subject to change without notice.
Actual shipping weight may differ due to extra packing materials for product protection.
* Depth does not include 1" for rear spacers.
† Height does not include 5" for caster height.

■ **WARRANTY : 5 Year Parts and Labor Warranty
7 Year Compressor Warranty**

■ **STANDARD FEATURES**

- **Anti-corrosion coated evaporator**
- **Self-contained system**
- **4" dia. swivel casters with locks on the front set**
- **1/6 size, 4" deep condiment pans included**
* Accommodates 1/6 size, 6" deep condiment pans

■ **OPTIONAL ACCESSORIES**

- 1" caster, 1/2" diameter & 13 TPI: S28R813660 (non-brake)
- 2.5" caster, 1/2" diameter & 13 TPI: 30265H0100 (non-brake), 30265H0200 (w/ brake)
- 5" caster, 1/2" diameter & 13 TPI: M726500100 (non-brake), M726500200 (w/ brake)
- Leveling leg, 1/2" - 13 TPI x 1.54": LFM1213566
- 6" ABS plastic leg: 30221M0200
- 6" stainless steel leg: 30221M0600
- Additional stainless steel shelf: M727800100 (Left/Right), M727800300 (Middle)
- Removable food cover: RCT-48
- Single overshef, stainless steel, 72-13/16" W: TSOS-6S
- Double overshef, 18/304 stainless steel, 72-1/2" W: TSOS-6R
- **Door lock: extra lead time will apply, please call factory for more details to order**

Ver.20230109

PLAN VIEW

(unit : inch)

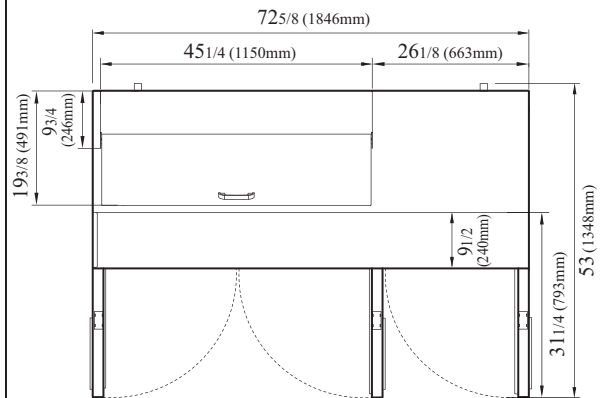

TST-72SD-12S-N
TOP VIEW

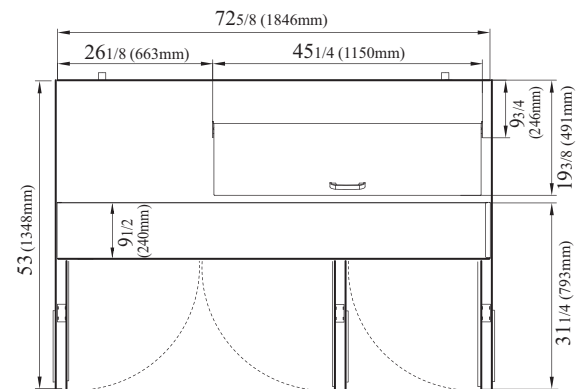

TST-72SD-12S-N-LW
TOP VIEW

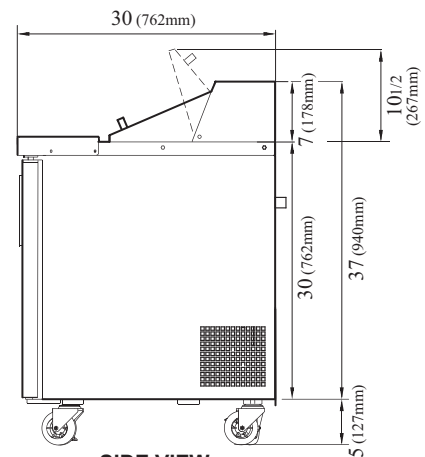

SIDE VIEW



- Turbo Air : 800-627-0032
- GK : 800-500-3519
- Warranty : 800-381-7770
- AC : 888-900-1002